

5th and 6th Grade Math Meet 2013

Name: _____ School: _____

EVENT 1: Problem Solving (no calculators)

Part 1: Decimals (2 points each)

1) $6.7 \times 8 =$

2) $2.6 \div 0.02 =$

3) $28.75 \div 5 \times 0.4 =$

4) $17.3 \times (7.96 \div 4) =$

5) A computer screen has a length of 13.8 inches and height of 10.4 inches. What is the area of the screen? (Label your answer)

5th and 6th Grade Math Meet 2013

Name: _____ School: _____

EVENT 1: Problem Solving (no calculators)

Part 2: Fractions (2 points each) (ANSWER IN MIXED NUMBER FORM)

1) $3\frac{1}{8} \times 2\frac{4}{9}$ _____

2) $2\frac{1}{4} \div \frac{3}{8}$ _____

3) Change 0.325 into simplest form (fraction) _____

4) Change $\frac{31}{25}$ into a decimal _____

5) Find the area of the rectangle in simplest form (label your answer) _____

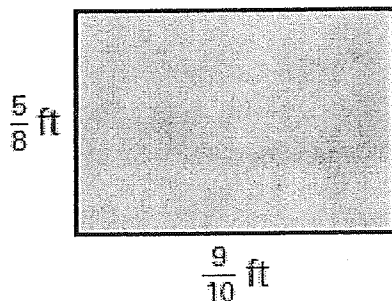

5th and 6th Grade Math Meet 2013

Name: _____ School: _____

EVENT 2: Consumer Math

(5 points each)

1. Tommy walks into the bank. He is in a line with 4 other people (5 total). How many possible ways can these people stand in line?

2. Tommy asks the teller at the bank to change his 14 quarters into nickels. How many nickels will Tommy get?

3. Tommy drives to the gas station to fill his car with gasoline. The gasoline costs \$3.30 per gallon. The gas tank in his car holds 16 gallons. He has 2.5 gallons currently in his tank. How much will it cost Tommy to fill his tank?

4. Tommy drives to Tampa with a full tank. His car gets 26 miles per gallon. Tampa is 364 miles away. How much gas will Tommy have in his car when he gets to Tampa? (Remember, Tommy's car has 16 gallons in his car's gas tank)

5. In Tampa, Tommy goes to a baseball game and buys 2 hot dogs, 2 sodas, 4 boxes of popcorn, and a baseball. He pays with a 50 dollar bill. How much change does Tommy receive?

HOT DOG - \$2.60

SODA - \$1.90

POPCORN - \$1.30

BASEBALL - \$4.99

5th and 6th Grade Math Meet 2013

Name: _____ School: _____

EVENT 3: Mathematical Reasoning

(7 points each)

1. Find the shaded area of the following object. Use 3.14 for π . Do not round your answer. (Label your answer)

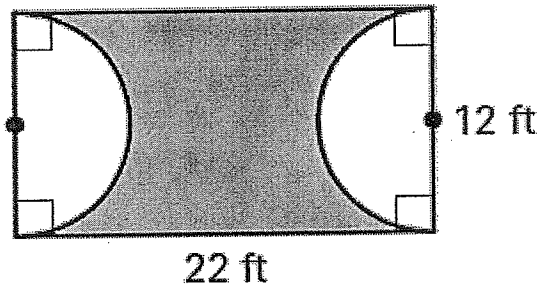

2. Find the shaded area of the following object. Use 3.14 for π . Do not round your answer. (Label your answer)

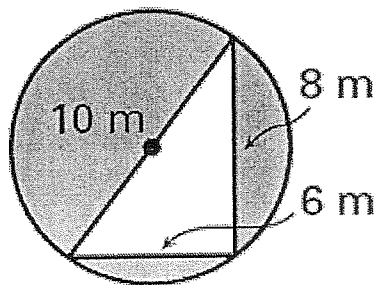

3. Find the surface area of the following object. (Label your answer)

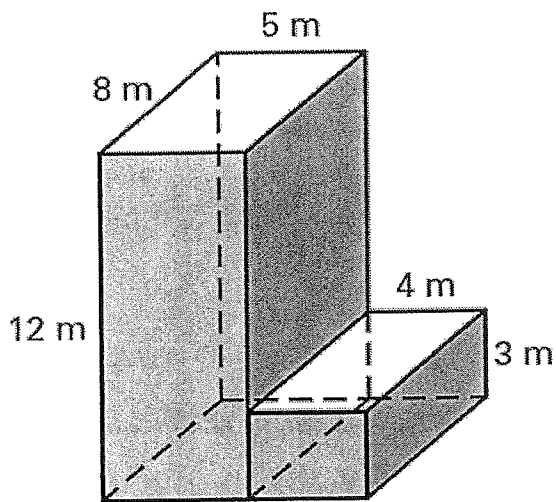

4. Use all the information to find the value of x .

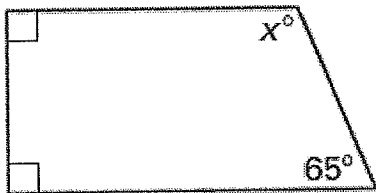

5. Use all the information to find the value of x .

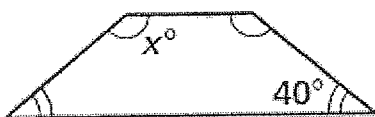

5th and 6th Grade Math Meet 2013

Name: _____ School: _____

EVENT 4: Mental Math (no calculators)

1 point for each correct answer

1) _____

2) _____

3) _____

4) _____

5) _____

6) _____

7) _____

8) _____

9) _____

10) _____

5th and 6th Grade Math Meet 2013

Name: _____ School: _____

EVENT 5: Team Problems (with calculators)

(5 points each)

A college uses two buses to transport students around campus. The map below shows the two bus routes and the number of minutes it takes to travel between stops.

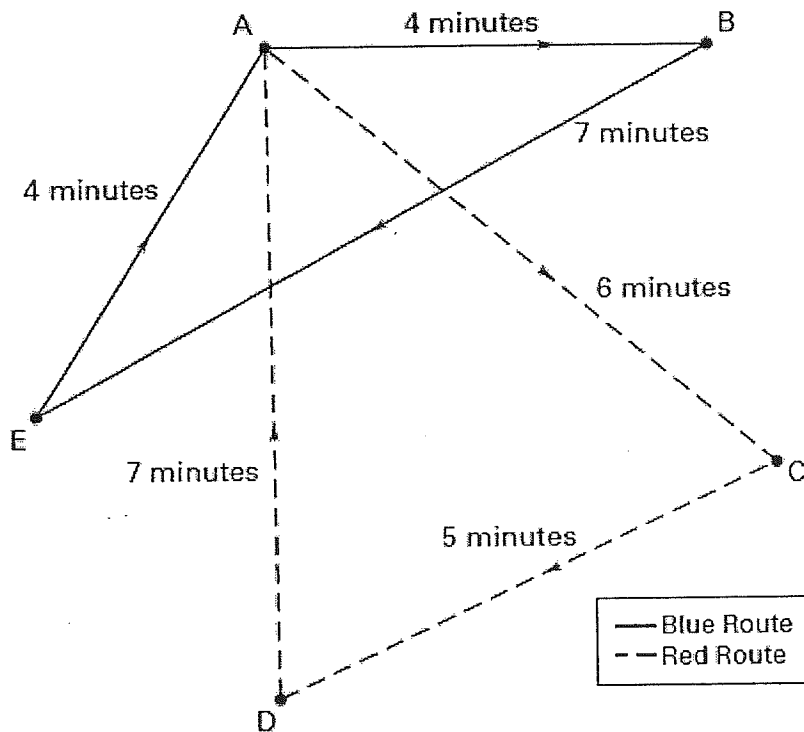

1. How long does it take the blue route to make one complete lap?

2. How long does it take the red route to make one complete lap?

3. If the buses leave point A at the same time, how long does it take for them to stop at point A again at the same time?

4. If the buses start running at 8am, what time is it when they first meet point A again?

5. You arrive at point A at 9:35am. How long do you have to wait for the bus on the blue route if it started running at 8am?

6. You arrive at point E at 8:50am. How long do you have to wait for the blue bus to pick you up?

5th and 6th Grade Math Meet 2013

Name: _____ School: _____

EVENT 5: Team Problems (with calculators)

(5 points each)

MENU

Hamburger - \$1.85
Cheeseburger - \$2.15
Fries - \$1.05
Small Soda - \$0.95
Medium Soda - \$1.25
Large Soda - \$1.55
Extra Large Soda - \$2.05

Find the total cost of the following orders

1. I want three cheeseburgers, one hamburger, a small soda, two fries, a medium soda, and another hamburger.

2. I want a cheeseburger and an order of fries with a medium soda. My son wants two hamburgers, an order of fries, and a medium soda. My daughter wants a cheeseburger, an order of fries, and a large soda. And my husband wants two orders of fries, a cheeseburger, and a large soda.

3. I'd like three hamburgers, a cheeseburger, three fries, a large soda, two medium sodas, and an extra large soda. Oh wait...add another order of fries to that and make one of those hamburgers a cheeseburger instead.

4. I would like to order 1 of everything on the menu and two more cheeseburgers...hold on, make one of those cheeseburgers a hamburger.

5th and 6th Grade Math Meet 2013

Name: _____ School: _____

EVENT 5: Team Problems (with calculators)

(5 points each)

Use the diagram of the basketball court to answer the following questions.

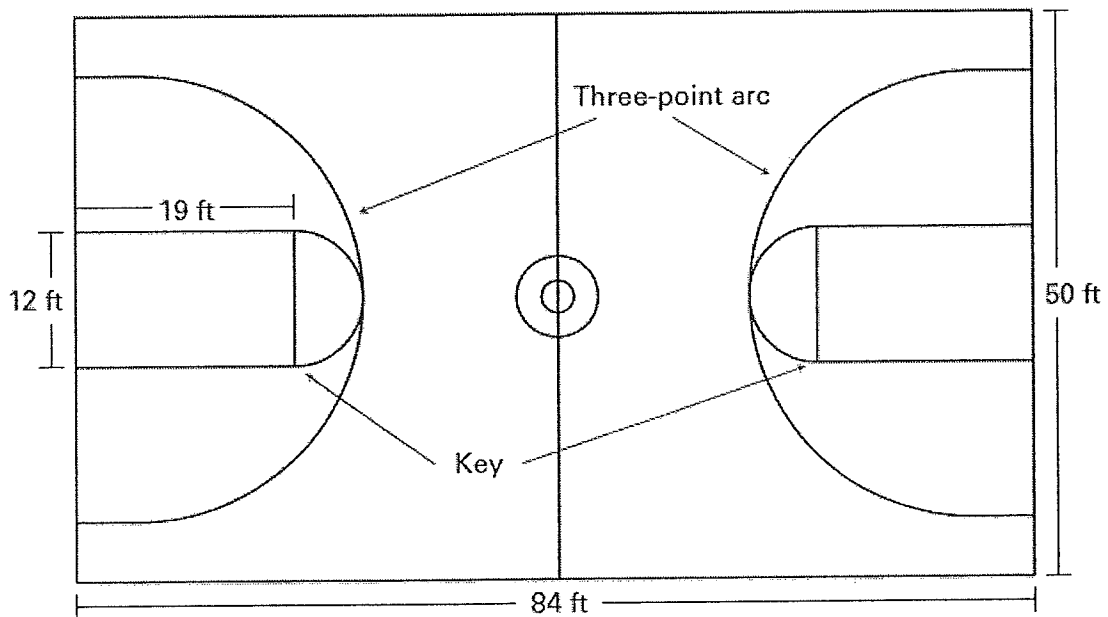

Label all answers

1. Find the area of the basketball court.

2. Each key is made up of a rectangle and a semicircle. Find the area of the rectangle in one of the keys.

3. Find the area of the semicircle in one of the keys. Use 3.14 for pi. (Do not round your answer)

4. What is the total area of one of the keys? (Do not round your answer)

5. How much of the total area of the basketball court is taken up by the two keys? Write your answer as a whole percent.

5th and 6th Grade Math Meet 2013

Name: _____ School: _____

EVENT 5: Team Problems (with calculators)

(5 points each)

You forgot the last two digits of your friend's phone number, but you know that both digits are less than 5.

(Answer all questions in fraction format in lowest terms)

1. What is the probability that the last two digits are 1 and 4, in that order?

2. What is the probability that one of the digits is 0 and the other is 2?

3. What is the probability that at least one of the digits is 3?

4. What is the probability that the last two digits are both odd?

5. What is the probability that the two digits are not the same number?
